

Selection of Copper vs. Aluminum Rotors for Induction Motors

Copyright material IEEE
Paper No. PCIC-2000-19

William R. Finley
Senior Member
Industrial Products Division
Siemens Energy & Automation, Inc.
4620 Forest Ave.
Norwood, OH 45212

Mark M. Hodowanec
Member
Industrial Products Division
Siemens Energy & Automation, Inc.
4620 Forest Ave.
Norwood, OH 45212

Abstract: On squirrel cage induction motors, there is an important choice between utilizing a lower cost die cast or fabricated aluminum rotor versus the more expensive copper bar rotor. Utilizing the wrong rotor construction for the application can either increase costs unnecessarily or lead to catastrophic failure. This paper will provide the background necessary to assist in making the proper choice. The fundamentals of rotor construction and basic information on how the induction motor works will be discussed. Additionally, the effects of various materials and types of rotor construction on motor performance will be analyzed.

Index Terms – Motors, Rotors, Rotor Construction, Copper, Aluminum Die Cast.

I. INTRODUCTION

Many induction motors in service today are running critical processes in which failure at any time can be very costly. Many times these critical processes will not have a back up. As a result a large portion of this process will shut down until the motor is repaired and put back into service. Those aware of this situation will strive to purchase a motor that will maximize reliability. As a result of the strong push for maximum reliability, it is easy to over specify costly components not required for the specific application. These decisions will result in an unnecessarily high motor purchase price. To maximize reliability without overspending, large induction motors need to be properly matched to the specific application. With this consideration the choice between various rotor constructions needs to be evaluated. It is generally assumed that copper bar rotors are the most reliable. In certain applications this may be true, and they can at times out perform aluminum rotors. But many times, the applications are such, that there will not be any appreciable performance benefit from the use of copper bar rotors. It will be shown later in this paper that the percentage motor cost increase can be very large on smaller machines but may not be as significant on larger machines.

With market conditions today, the economics are such that users and engineers are looking for the best fit for the application at the most reasonable cost. As a result they are looking at purchasing motors utilizing aluminum die cast rotors in ratings to much greater horsepower than what was considered practical in the past. Due to advancements in aluminum die-casting technology, reliable die-cast rotors are now available in motors up to much larger ratings. Also available are fabricated aluminum rotors, which have a

performance characteristic closer to the aluminum die cast rotor, but with a higher cost due to the labor cost associated with fabrication. All this will be discussed in greater detail later in the paper.

II. ROTOR CONSTRUCTION

Four types of rotor construction exist today: aluminum die cast (ADC), copper die cast (CuDC), fabricated aluminum bars (AlBar), and fabricated copper bar (CuBar). In general, only the aluminum die-cast, fabricated aluminum, and copper bar rotors are in common use today. At this time this paper will discuss how these are manufactured.

Aluminum Die Cast Construction (ADC):

Aluminum die-cast rotors have been manufactured since the 1930's. Although this process has been utilized for a long time, the rotor sizes that can be die cast increase each year due to manufacturing advancements in die cast technology. Current state of the art technology makes it possible to die cast aluminum rotors with a 30" diameter and a 50" core length. This is the size rotor that would be capable of producing 10,000 Hp. However, due to tooling costs and demand it is unusual to see ADC rotors used in ratings above 1750 HP.

The aluminum rotor is constructed utilizing the following steps:

- 1.) Stack rotor punchings on a stacking mandrel.
- 2.) Insert punching/mandrel stack in end connector mold.
- 3.) Die cast (i.e. inject aluminum) rotor.
- 4.) Insert shaft into hot rotor core.
- 5.) Turn & balance rotor assembly.

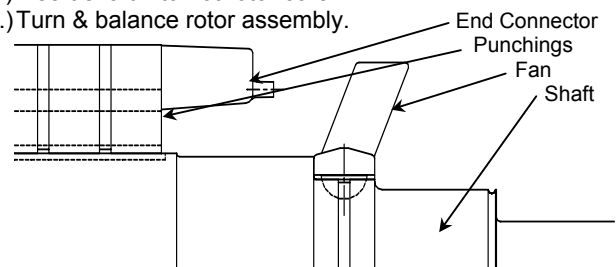

FIG. 1 - ADC Rotor Cutaway View

The basic process has been unchanged since its inception. But, as is always true, the quality and integrity of the end results is strongly based on attention to detail, and using

state of the art technology. In the case of die cast rotors, the following details are important:

- Tight tolerances and close fit of the punching ID to stacking mandrel. This will minimize lamination stagger. The benefits to minimal stagger are twofold: minimization of stray load loss and thermal sensitivity. Minimizing stray load loss will result in not only a cooler running motor, but higher efficiency as well. Minimizing thermal sensitivity (i.e. change of balance as the rotor heats up) will result in having a motor that maintains low vibration levels cold or hot.

- Rotation of rotor punchings while stacking on mandrel. The sheet steel roll that the rotor laminations are punched from will have variation in thickness from one side of the sheet to the other. If the punchings are not rotated, then the thick side will all stack up on one side causing a 'banana' shaped rotor. Although the rotor will be machined and trued up, it will still exhibit more thermal sensitivity than a rotor that was stacked 'straight'.

- Consistency of die cast clamp and shot pressure. This will help assure that the die cast aluminum is homogeneous, and does not 'leak out' between the laminations or vent spacers. If aluminum leaks out anywhere, there will be increased porosity in the adjacent rotor bars. Additionally, it should be pointed out that aluminum shrinks 6% on cooling (i.e. there will be 6% porosity in an aluminum die cast rotor). If the shot process is not properly controlled (i.e. shot pressure and shot velocity vs. shot ram position), than this 6% will be unevenly distributed. Instead of having an even dispersion of fine 'bubbles', there will be large, non-evenly distributed blowholes. This will result in an increase in resistance in the bar(s) with the blow holes, with a subsequent increase in the bar temperature relative to the temperature of other bars. This in turn will cause the rotor to exhibit a high degree of thermal sensitivity. Increased clamp pressure results in an increase in interlaminar core pressure. The eddy current portion of core losses goes up as interlaminar pressure increases. Additionally, if the clamp pressure (and thus core pressure) is uneven, thermal instability can be a problem. Increased core losses can also occur as a consequence of some of the aluminum leaking out between the laminations. In either case, increased porosity (blow holes) or excessive core pressure will result in hotter, less efficient motor operation.

- 'Good Modern Die Cast Practices' these practices include cavity vacuum before the die cast 'shot', computer monitoring of 'shot', temperature controlled die, etc.

- Shaft should be inserted into a hot core so as to minimize mechanical stresses associated with the pressing operation, and allowing the core to shrink onto the shaft symmetrically. This will help ensure symmetrical thermal expansion when the motor in operation heats up. The hoop strength of the core as it shrinks on to the shaft should be sufficient to maintain the shrink fit. The shrink fit on shaft must be adequate to transmit the torque at maximum speed and temperature.

Properly designed, manufactured, and applied, aluminum die cast rotors have the same degree of reliability as copper bar rotors.

Copper Die Cast Construction (CuDC):

CuDC construction does not differ significantly from ADC construction. The CuDC imposed manufacturing challenges that only recently have been met.

In essence the manufacturing details for CuDC are identical to ADC. The additional manufacturing challenges are increased temperatures and pressures required to die cast copper. As illustrated in the table below, CuDC requires higher temperatures and pressures as compared to ADC.

	Al	Cu
Temperature	1200 F	2000 F
Shot Pressure	2000 PSI	6500 PSI
Clamp Pressure	2400 PSI	7800 PSI

Although CuDC is a much newer technology, current state of the art technology makes it possible to die cast similarly sized rotors in copper as can be cast in aluminum. The integrity and reliability of CuDC is just as good as in ADC. The primary reason CuDC rotors are not commonplace yet is because it's a new technology and requires a large capital investment.

Fabricated Aluminum Bar Construction (AlBar):

Although many people associate 'aluminum rotors' to mean 'Aluminum Die-cast', fabricated aluminum bar rotors can be built. The primary advantage of AlBar over CuBar is cost. The primary advantage of AlBar over ADC is that most manufacturers have some finite limitation on the size that they can successfully manufacture an ADC rotor and the tooling cost required to die-cast a rotor. While there are many similarities of AlBar to CuBar construction, there are two notable differences: the end connector of an AlBar rotor is welded to the rotor bars (as opposed to brazed), and, the end connector of an AlBar rotor clamps the rotor punchings (as opposed to end heads). It should be noted that AlBar rotors can also be built with a construction method similar to CuBar rotors, but this method is more expensive and not as common.

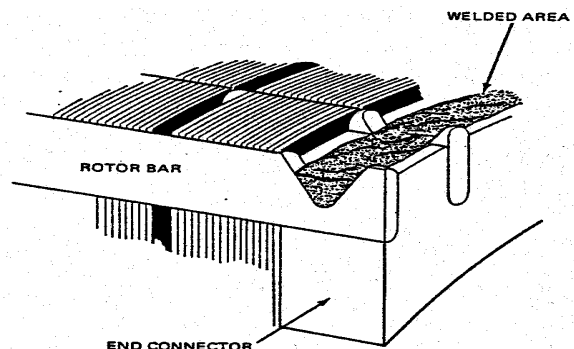

FIG. 2 - AlBar Rotor Cutaway View

The AlBar rotor is constructed utilizing the following steps:
 1) Stack rotor punchings on a stacking mandrel.

- 2) Hold punchings and end connector clamp assembly together.
- 3) Insert shaft into hot core.
- 4) Insert bars.
- 5) Machine end of bars.
- 6) Weld end connector to bars.
- 7) Turn and balance rotor assembly.

Some of the key points to assure that the highest quality & reliability is obtained when manufacturing AlBar rotors is:

- Consistent & controlled clamp pressure – see CuBar section for additional explanation.
- The rotor bars should be shimmed and center swaged or locked in such a way the bars don't ratchet themselves out of the core – see CuBar section for additional explanation.
- Welding directly on the shaft should be minimized. Any welding will result in residual stresses and potential thermal instability.
- Proper core and bar temperature to avoid excessively high residual stresses when core cools.

Fabricated Copper Bar Construction (CuBar):

CuBar construction is the oldest, dating back to the 1920's. Although it is possible to manufacture CuBar rotors in any size, economics will make this choice unattractive for small motors.

The fabricated copper bar rotor is constructed utilizing the following steps:

- 1) Stack rotor punchings on a stacking mandrel.
- 2) Hold punchings together along with end heads. Clamp assembly together
- 3) Insert shaft into hot core, lock core in place without welding.
- 4) Insert bars.
- 5) Machine end of bars.
- 6) Braze end connectors to bars.
- 7) Turn and balance rotor assembly.

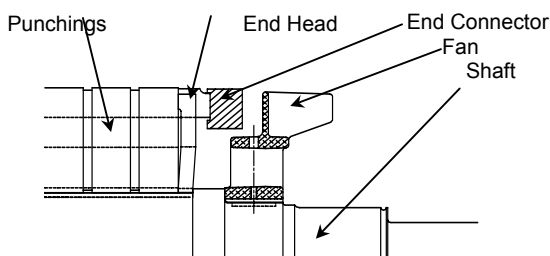

FIG. 3 - CuBar Rotor Cutaway View

The basic process also has been unchanged since its inception. Some of the key points to assure that the highest quality & reliability is obtained when manufacturing CuBar rotors are:

- Consistent & controlled clamp pressure. Consistent clamp pressure applied uniformly to laminations will minimize the thermal sensitivity of the rotor assembly. While the clamp pressure should be consistent, it should not be excessive. Excessive clamp pressures increase core losses.

- The end connectors should be induction brazed to the bars. In addition, the temperatures of both the end connectors and bars should be continually monitored throughout the brazing process. Induction brazing results in much more consistent temperature distribution than is possible with flame brazing. Additionally, it heats the end connector, which in turn heats the bars. This will minimize the amount of heat that the rotor core will have to absorb. Both of these mechanisms will minimize the amount of residual stresses present in the end connectors, bars, or braze joint. In addition, the rotor will exhibit less thermal sensitivity than a flame-brazed rotor.

- Tight rotor bars! Loose rotor bars is the number one cause of CuBar rotor failure. See subsection below on tight rotor bars.

- End heads designed in such a way that they exert constant clamping force. Even if the lamination clamping portion of the end head is axially displaced, it will exert a constant clamping force on the rotor punchings. The rotor will grow thermally, if the end heads are overly rigid they will exert too much clamping force, resulting in increase core losses.

- Welding directly on the shaft should not occur unless stress relieved afterwards. Any welding will result in residual stresses and potential thermal instability.

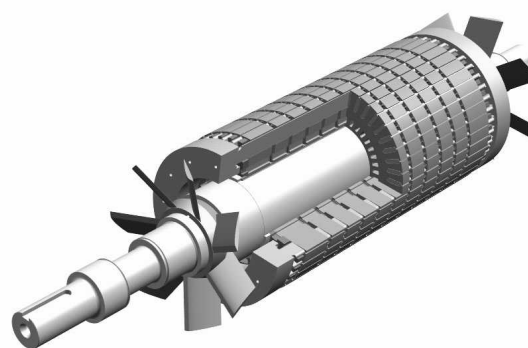

FIG. 4 - 3D CuBar Rotor Cutaway View

III. HOW TO ACHIEVE TIGHT ROTOR BARS

Loose rotor bars is the number one cause of CuBar rotor failures. At starting, the rotor bars oscillate at:

$$\text{Rotor Bar Vibration Freq.} = 2 \times \% \text{ Slip} \times \text{Line Freq.}$$

The rotor bars vibrate as a consequence of high current forces [6]. If the bars aren't firmly seated, they will break over time. There are many different methods to achieve tight rotor bars, some methods may be better than others, but all can work reasonably well if properly performed.

In one method bars can be driven into the slot then swaged. Swaging is performed by pushing down at the center of the top of the rotor bar as show in Fig. 5. It must be pressed down deep enough to bulge the bars out on the side and fill in the gap between the bars and the core.

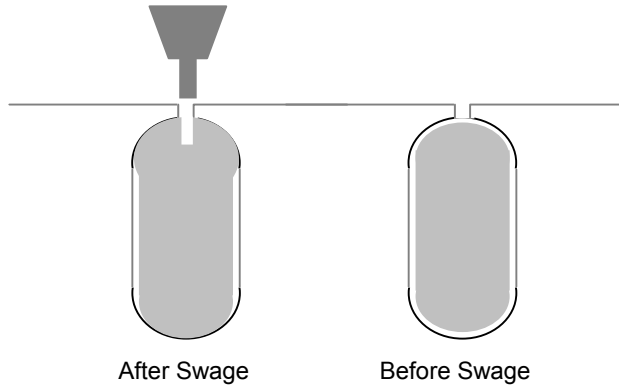

Fig. 5 - Rotor Bar Swaging

Note this will not work on many shaped rotor bars, which rely on the lower part of the bar to produce the tight fit, as a result some other method must be performed here. With many of these bar shapes, if the upper section is swaged, the thermal stresses when the bar expands in height will tend to crack the bar where it connects with the heavier section as shown in Fig. 6.

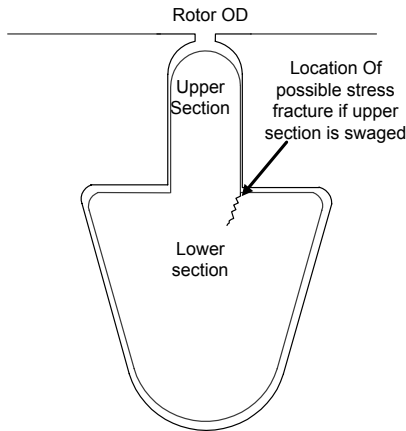

FIG. 6 - Shaped rotor bar

An alternate method to ensure tight rotor bars, is to cool the bars in dry ice and then insert them into a warm core. The bars will tighten when the temperature equalizes.

In still another method, bars can be pressed into a core, which is lined with steel shims. These thin shims of various thicknesses' can be sized appropriately to ensure that the bar is tight in the slot (Fig. 7).

This gives a smooth surface for the bars to be driven through allowing the bars to remain tight throughout the length of the bar to core fit. In this case, the bars normally only required center swaging, so that bars are located axially and thermal creeping does not occur. The benefit of shimming is three fold. Firstly, the shim thickness can be selected to minimize the amount of rotor bar looseness. Rotor bar size tolerances, slot size, and slot stagger (misalignment of one lamination relative to the another) will

vary the required shim thickness to ensure tight rotor bars. Thus, tight bars can be obtained without full length swaging. Second, a rotor bar will not have its copper eroded as it is driven through the core. When a rotor core is stacked there will always be a certain amount of stagger in the core. The copper bars are much softer than the steel laminations, and as they are driven through, will have some material shaved off. Thirdly, the shims will let the bars thermally expand and contract easily and without binding. Binding would cause the bars to ratchet out of the core or erode due to movement over time. All three mechanisms will minimize the thermal sensitivity of the rotor.

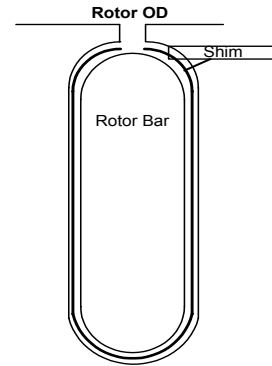

FIG. 7 - Rotor Bar & Shim

IV. ROTOR STRESSES

Now that the basic construction features are understood, stresses resulting from manufacturing processes, and operation can be discussed. Much attention is paid to the design process to make sure that stresses are within acceptable levels. It is not the intention of the authors to describe the stress analysis in great detail here, but rather discuss these stresses from a qualitative perspective.

Rotational Stresses:

Rotational stresses occur as a consequence of centrifugal force. These stresses occur in any rotating component, however, the larger the radius of rotation, the larger the stress will be. The rotational stresses are insignificant in the bars. However, the same is not true for lamination stresses. The area above the bars is particularly affected as the laminations not only are stressed as a consequence of their own mass, but also have to provide the retaining force to keep the rotor bars in place. This retaining force exerts further stresses on the laminations. Copper bars are approximately three times heavier than aluminum, so there must be sufficient strength in the laminations above the bars. This in turn forces designers to locate the bars somewhat deeper radially into the core than aluminum bars.

End connector stresses may be significant. Generally, for similarly sized rotors, aluminum rotors can tolerate higher speeds because of their lower density. If the speeds are sufficiently high, than high strength retaining rings can be used which will allow the end connector to tolerate a higher

speed. These high strength end retaining rings can be used on aluminum or copper end connectors.

High strength retaining rings are placed on the outer diameter of the end connector. There is an interference fit while the rotor is at rest. This interference fit results in an initial compressive stress on the end connector, and a tensile hoop stress on the retaining ring. As the rotor is brought up to speed, the centrifugal force causes the retaining ring to lose some of its initial interference. In the process, the retaining ring tensile stress increases. At the same time, the initial compressive stress on the end connector becomes less compressive, and as the rotor speed increases transforms into a tensile hoop stress. At full speed, the tensile hoop stress of the end connector is less than what it would have been without the retaining ring. For comparative purposes review the table for the strengths of the various materials used in rotor construction [10].

	Yield	Tensile
Aluminum	4	10
Copper *	10	32
Alum-Bronze	60	110
A286 Stainless	100	146

In the above table the strengths are in KSI (PSI/1000). It should be noted that the strength of copper is at a .5% offset, and not the .2% offset that is normally used for metal strength determination.

Residual Stresses:

Residual stresses arise as a result of the manufacturing process. In general, in all of the construction methods utilized, the initial stresses will be higher than yield strength of the material. For example, when a ADC rotor is die cast, the aluminum will start solidifying at 1200° F. The coefficient of thermal expansion of aluminum is 100% greater than that of steel. As the rotor cools to ambient temperature, a force is exerted on the iron stack by the shrinking aluminum bars (which have already froze). The force is great enough to cause the aluminum bars to yield. Residual stress in the copper construction is somewhat different. Since the end rings are not up against the core when brazed, axial stresses do not exist. However, bending stresses due to end ring thermal expansion still do exist. When the end connector is brazed to the rotor bars, the end connector is heated to over 800° F, which causes it to expand radially. The core temperature is slightly elevated, but nowhere close to 800° F. On one end, the bars are constrained from moving by the core, and at the other end the bars are forced to move with the end connector. The bars are thus put in a bending mode and shear mode, resulting in initial stresses that exceed the bars/end connectors yield strength. Although high residual stresses exist, rotors have been successfully built for many years utilizing these construction techniques.

V. FUNDAMENTALS OF INDUCTION MOTOR OPERATION

To properly select the optimal rotor construction method, it is important to understand how a “squirrel cage rotor” in an

induction motor works. Additionally, an understanding of how different performance characteristics can be achieved by altering the rotor design is necessary. It is not intended here to give enough detail to design induction motors. However, the fundamentals need to be adequately understood so that one can understand the relative tradeoffs between different types or rotor construction.

On AC Induction motors, a voltage is applied to the stator. At no load this voltage produces a current that along with the number of stator winding turns on the coil supplies the necessary ampere-turns required to establish the rotating magnetic field. This fundamental flux rotates at a speed that is dictated by the number of poles and the frequency of the voltage applied to the stator winding. When voltage is applied to the motor terminals, while the motor is not rotating the rotor winding is in effect short-circuited. This is similar to the short-circuiting of a transformer secondary. In this condition, the rotor voltage and current is high, and is at the same frequency as the applied stator voltage. Note that once the rotor is at speed running idle, it rotates at a speed nearly identical to, or in synchronism with, the rotating magnetic field in the stator. Therefore the magnetic flux lines cut through the rotor bars very slowly. As a result the voltage, frequency, and current in the rotor bars approach zero. As load is increased the rotor slows down and begins to slip behind the stator rotating magnetic field. This slip can be expressed in RPM as:

$$\text{slip RPM} = (\text{synchronous RPM} - \text{actual rotor RPM}).$$

Because the rotor slows down the stator magnetic field cuts through the rotor bars at an increased rate. This induces greater voltage and current in the rotor bars at a higher frequency. The current in the rotor bars creates a magnetic field in the rotor that rotates synchronously with the stator magnetic field, but at an angular displacement to it. The magnitude of each magnetic field along with the angular displacement between the stator and rotor produces torque that resists the slowing down of the rotor. When this torque equals that of the load, steady state is reached. In short, current in the rotor bars changes in magnitude and frequency (along with slip) as necessary to produce the required load torque.

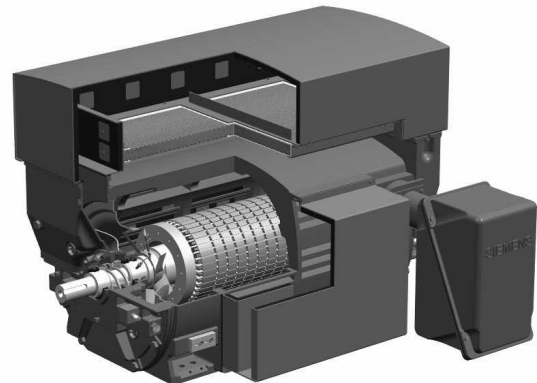

FIG. 8 - Cut away view of motor with rotor

Per unit slip is equal to the power in the rotor copper divided by the power across the air gap, P_{Cu2}/P_{gap} . So as a result, for a given output power, slip is proportional to the rotor I^2R loss.

Also, for a given design, slip is proportional to power output but rotor I^2R losses will vary as the square of the load current. Slip can also be expressed in percent per the following equation.

$$\% \text{ slip} = 100 \times (\text{SYN. RPM} - \text{Loaded RPM}) / \text{Sync RPM}$$

Since for a given output power slip is proportional to the I^2R loss of the rotor, the greater the rotor bar resistance the greater the slip required to produce rated load. Also, along with this comes increase temperature rise and lower efficiency.

Locked Rotor Torque:

Another item to keep in mind is that the locked rotor torque is proportional to the I^2R loss in the rotor at zero speed. The greater the rotor resistance is the greater the torque will be for a given locked rotor current. However, if the rotor bar resistance is doubled, the locked rotor torque will not be doubled since the rotor slot impedance, which is the sum of rotor slot resistance and reactance, will increase with rotor bar resistively, thereby decreasing locked rotor current and therefore torque. Also the depth of penetration of the current in the rotor bar due to the skin effect increases with increasing resistively. Skin effect is the distortion of the current distribution and increase in the effective resistance caused by high frequency stray leakage fluxes passing through the copper, which generate local voltages and eddy currents in the process [8]. For example a bar with pure copper 1.0 relative resistivity will have current flowing in approximately the upper (closer to air gap) 3/8 inch of the rotor bar at zero speed on a 60 Hz. power supply. Where as a bar with 1.8 relative resistivity, (CDA 210 or pure aluminum), will effectively have current flowing in approximately the upper 1/2 inch of the rotor bar thereby increasing the effective conducting area and decreasing rotor loss and torque at locked rotor. Therefore, the torque at zero speed will not be 1.8 time the torque of the lower resistance bar.

The example in Table I may better explain the performance variation with different rotor bar materials. In this example there is no change in the stator winding or rotor bar dimensions except the first ADC rotor has a larger slot area totally fitting the total area available in the rotor. In addition, this example is for an open 2-pole motor where windage and friction loss can be significantly effected by rotor construction. This would not be as noticeable on slower speed motors and more benefit in efficiency would be seen by the use of pure copper. It should be noted that in this above example that the LRA decreased as the rotor bar resistance increased. In an actual design the stator winding would then be changed until the current was back up to a more normal level and as a result the torque would increase more closely proportional to the increase in effective resistance. Remember the effective resistance is somewhat reduced due to the depth of

penetration of the current into the bar. This is different to the condition where the stator remains unchanged and the voltage is increased thereby increasing the current proportionally to voltage plus a small percentage more due to saturation. In this condition the LRT will increase proportion to the square of the LRA.

Electrical Performance:

Normally aluminum die cast rotors are limited on rotor bar conductivity due to the logistics of having multiple die-casting machines or aluminum storage tanks for the molten aluminum. On smaller NEMA size machines copper or aluminum fabricated rotors are not available as standard primarily due to higher labor cost associated fabricated constructions. Copper bar rotors come in many different alloys with relative resistivity ranging from 1.0 to 10. Fabricated aluminum rotors come in a few alloys ranging from 1.8 to 3.0.

Rotor Bar Heat Capacity:

Aluminum rotor bars have approximately 1/3 the density, weight and 2.5 times the specific heat of copper bar rotors. The coefficient of thermal expansion for a given temperature change is 35% greater on aluminum than copper and at the same time aluminum has lower strength as shown in the Table II. As a result of the material density and specific heat, aluminum bars will get much hotter, expand further and generate much higher stresses while accelerating the same WK2. The bars will expand more and what could be a more serious issue is the end ring thermal expansion that will cause stress on bar where it exits the core and connects with the end connector. On ADC rotors and some fabricated aluminum rotors the end connectors are up against the core. There may only be a slight transition coming out of the slot and there is minimal allowance for movement in that location. As a result there is little room for the bars to bend and the stresses could be high at that joint. On fabricated copper bar rotors that have copper or copper alloy end connectors besides having 2.5 times the thermal capacity they are also located greater than a 1/2 inch away from the core distributing the bending stress along the extension. This rotor will have a point of high stress either at core or at the braze joint on the end connector. The end connector is normally the point of highest stress. In general, all types of rotor construction have stresses that are beyond the material yield point in this area. However, this area is not subject to high frequency cyclical reversing stress. The number of thermal cycles that the rotor bars and end connectors will see due to this phenomenon will be equal to the number of starts. For reference, API 541 recommends capability for a minimum of 5000 starts.

Efficiency:

It is a common misconception that copper bar rotors will always produce better efficiency and greater locked rotor torque. This is not necessarily true. If a copper bar is used to increase locked rotor torque, normally a higher resistance bar would be used. As can be see in Table I when a 4.0 resistivity bar is used to increase torque the losses and

temperature rise will be greater and the efficiency will be lower. Now if a pure copper bar is used, the LR torque will be less but the efficiency could be greater unless the copper bar rotor has an increase in windage loss as could be commonly seen on 2 pole motors due to the turbulence of the rotor bar extensions. It should be pointed out that in the example in table I, the aluminum bar shape could be optimized to a point where the area was much greater than with the copper bar rotor. This normally would not be the case on slower speed machines and the windage and friction would not be substantially higher. As a result efficiency would normally increase 0.2% to 0.5% Normally it would be difficult to justify the expense of the copper bar rotor just for improving efficiency especially on smaller machines.

Rotor Design Flexibility:

From an economic and practical point of view a copper bar rotor design is more flexibility to changes in rotor bar resistivity. Copper bars and alloys are available in many different resistances and no change in tooling would be required. Of course, some of the more exotic alloys can get quite expensive on a price per pound basis.

The aluminum die cast rotor is flexible from the point of view that the bar takes the shape of the rotor slot. On smaller machines where combination dies are used and a change in slot shape can cost a quarter-million dollars, this may not seem very flexible. But on the larger machines that use single slot dies (that range in cost from two to three thousand dollars), new dies may be more practical. Once the investment is either made in the die whether they are the low or high cost version, future rotors can be economically produced.

VI. STARTING

During starting there are basically four motor components which are adversely affected by the heating and mechanical affects of starting. These would include the end connectors, the rotor bars, the stator winding, and the shaft extension from the core as a result of the transient torque transmitted through the shaft. For the purposes of this paper we will limit discussions to the rotor bars and end connectors. For a more comprehensive analysis of rotor shaft failure, Ref. [9] should be consulted.

It has been proven by experience that the most damage is typically done to the rotor bars and end connector during starting. A stalled condition can be even more severe but this is an abnormal condition and should be avoided since it can lead to rapid catastrophic failure. Each motor is designed for a limited number of starts. For example API 541 recommends a minimum of 5000 starts while starting a load and inertia as defined by NEMA. A NEMA square load curve is defined as a torque vs. speed curve where the load torque varies as the square of the speed up to 100% load at 100% speed.

During starting, the RMS current can approach 650 % of full load current and will flow primarily in the upper part of the rotor bar near the rotor OD at zero speed due to the skin

effect. The current will distribute down to the lower part of the rotor bar (towards the rotor ID) as the motor comes up to speed and the frequency seen by rotor bar decreases. One final thought on starting: The fatigue life of the motor and its various component is inversely proportional to the number of starts. Each start takes the rotor and other various components through one thermal fatigue cycle and subjects the rotor bar to high frequency (rotor bar oscillation frequency) vibration. Both conditions are stressful on the various rotor components.

The following sections discuss stresses associated with starting a rotor. In particular, stresses resulting from high frequency start up vibration and thermal cycling (especially on extended starts) will be discussed.

Bending of Rotor Bars during Starting:

Any time a rotor is started, the rotor bars and end connector go through intense heating. The primary effect of this intense heating is the bending of the bars and the subsequent stress on the bars, end connectors and bar to end connector joints.

Each time the motor is started, the end connectors expand more rapidly than the rotor core. This happens because the coefficient of thermal expansion is 50% to 100% greater for rotor conduction materials than that of lamination steels [7]. Additionally, the heat is introduced so rapidly into the bars and end connector that only a small fraction of the heat will transfer into the rotor core. The bars are constrained by the laminations, resulting in bending stress in the end connector to rotor bar joint. In addition, the section of the rotor bar closer to the air gap carries all the current due to the skin effect. This in turn causes the bars to be heated more at the top of the bars than at the bottom as illustrated in Fig. 9. As a result, the top portion of the bar expands axially faster than the section closer to the rotor bore causing the bar to bow inward as illustrated in Fig. 10. The only place the bar can bow is external to the rotor slot again causing higher stresses at the connection to the end connector.

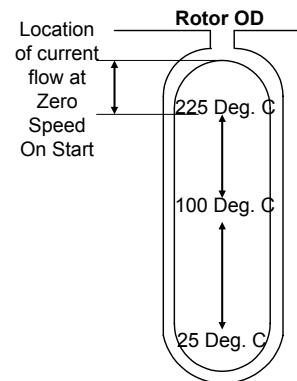

FIG. 9 - Typical Thermal Distribution for High Inertia Start on a Copper Bar Rotor

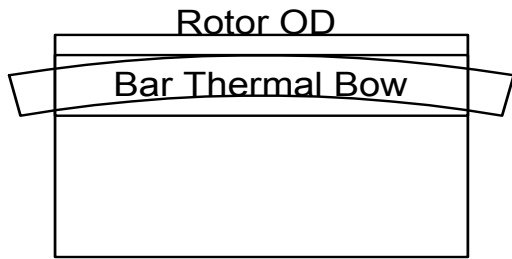

FIG. 10 - Rotor Bar Thermal Bow Due to Heat Distribution

Vibration of Rotor Bars during Starting:

As stated before, the current density in the bars is at its greatest at zero speed. The frequency of the current in the rotor bars is 60 Hz on a 60 Hz power supply. Every time the instantaneous current in the bars reaches the maximum, force pushes the bar away from the rotor OD and every time the current goes through zero the force on the rotor bar returns to zero. As a result at zero speed there is an oscillating force at 120 Hz attempting to vibrate the bar radially. This in turn causes high stress at the joint between the bar and the end connector. As the rotor comes up to speed the centrifugal force acting on the bars will force the bars to the OD minimizing movement, and thus, vibration. Additionally, as the rotor comes up to speed, the current decreases, thus reducing the vibratory force. Many times the stresses in this joint caused by vibration exceed the endurance limit of the bars, and consequently, the bars have a finite life. This can be minimized if the bars are manufactured to be tight in the slot as previously discussed.

The number of starts and fatigue life of the motor and its various component is inversely proportional to the number of starts and the duration of the starting cycle (i.e. acceleration time). Acceleration time is directly proportional to WK2.

Even if the bars are tight, significant thermally induced stresses exist, which may potentially cause another mode of failure.

Adverse Effects of Starting High Inertia Loads:

High inertia starts result in rapid bar heating and can adversely affect the life of the motor. Rotor bar failure is even a greater concern when the application requires multiple restarts of a high inertia load. In these applications copper bar rotor should be considered. Reasons for consideration were discussed in the 'Rotor Bar Heat Capacity' section. The copper bar rotor will have more thermal capacity and therefore less heating and thermal expansion than aluminum rotors. The bar material will have higher strength. In addition, the bar extension will allow for some bending in the transition section between the bars and end connectors thereby lowering the mechanical stresses. Of course, if the load or inertia is too great, the bars and end connector can overheat and lead to rapid catastrophic failure, no matter what the rotor construction is. The use of a copper bar rotor cannot be a substitute for good design practice or the proper understanding of the application.

On ADC rotors the bars are not able to bow significantly so the outer part of the bar tries to push the end-connector axially away from the core while the section at the smaller diameter tries to hold the end connector closer. This creates high stress at the end connector joint. It should be pointed out that though there are stresses along the length of the rotor slot they are much lower and have rarely been seen to cause a failure in the slot. The only time a failure could typically be seen in the slot area is on ADC rotors where the rotor bar is heated to a point where the aluminum melts. This can happen as a result of excessive heating due to a stalled condition, single phase, excessive inertia/load on start up, or as a result of multiple hot starts. All these conditions can cause rotor bar failure near the center of the core at what could be its hottest point or at the joint to the end connector.

As can be seen in Fig. 11 with the end connector so close to the core on the ADC rotors, the bars don't have a transition area in which to bend, therefore the concentrated stresses can be much greater than on a copper bar rotor. This is another reason why copper bar rotors can withstand high inertia loads better than ADC rotors. However, if the inertia is not high or the application does not require a considerable quantity of long duration starts over the life of the motor, stresses will be low and the heating will be more evenly distributed, and the ADC rotor will perform just fine.

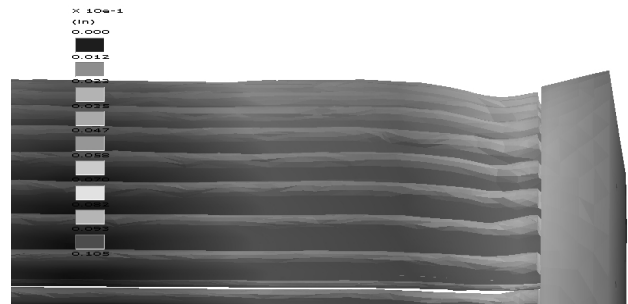

FIG. 11 - FEA Model of Rotor Bar Bending during Startup

VII. ROTOR BAR REPAIR

If it becomes necessary to repair a failed rotor in the field, it is certainly easier to accomplish this on a fabricated rotor than an aluminum die cast rotor. If an aluminum die cast rotor fails it is virtually impossible to get access to the failed area. It will either be buried in the core area or at the end connector up against the core. In either case it will be hard to access. Most fabricated aluminum rotor designs also have their end connector up against the rotor core and would have some difficulty but there is a chance that the end connectors could be replaced. There is considerable technology involved in manufacturing aluminum-fabricated rotors and if the repair facility doesn't understand the technology reliability would be very questionable. Most service shops have more experience repairing CuBar rotors than AlBar.

If an ADC rotor needs the bars replaced, it would be difficult, if not impossible, to acquire bars to fit the slot. In addition, the core is normally held together by the rotor cage and would be challenging to assemble. The most practical

way to repair is to die cast a new core. This is normally not possible in a service shop and most probably will have to be done by the original motor manufacturer. Some service shops have been known to 'rebar' ADC rotors using copper bars in emergencies, but it is costly in both material and labor.

In contrast, the fabricated copper rotor construction allows for relative easy access to the end connector braze joint where repairs can be made or new end connectors can be brazed on. If the cage needs to be replaced, rotor bars can be purchased, installed and new end connectors brazed on. Economically it is not justifiable on smaller machines to purchase motors with copper bar rotors, and, in many cases they may not be available. But if getting the motor back into service quickly in a critical process is a major concern, a CuBar rotor still deserves consideration.

The reader should also be made aware that while copper bar rotors are repairable, in general a replacement aluminum die cast rotor can be manufactured at a lower cost compared to a rotor 'rebar'. The primary disadvantage here is that only the original motor manufacturer has the laminations and die casting equipment necessary to do this and the longer delivery may be an issue.

VIII. ADJUSTABLE SPEED DRIVE (ASD)

Generally, the ASD starting condition is very soft and does not produce large radial forces. The load current rarely exceeds 150% of rated current. Subsequently, there will not be a high level of thermal expansion and stress on the bars or end connector as a consequence of ASD 'starting'. At first look one might think the bars may not need to be tight. However, experience indicates quite the contrary. While fatigue and failure during startup is not a big concern, tight bars are still essential to ensure low vibration levels at all speeds. Since the motor can only be balanced at one speed it is critical that the bars and the entire cage don't shift as the motor changes speeds. ADC rotors are ideal for this application since the cores are die cast in such a way that the aluminum fills the slot entirely, and there is little chance of any rotor bar movement. On high speed motors copper and fabricated aluminum rotor bars must be even more securely tightened in the slot than motors intended to be used for across the line start, but this time for reasons of low vibration.

ADC rotors may not be better in all aspects in ASD application, but they are quite reliable with respect to vibration and may be able to go to higher speed due to their lighter weight. Their lighter weight is a consequence of lower density bar material and results in higher critical speed and lowers centrifugal force on the various rotor components. They do have a pitfall, since the rotor bar resistance is higher than pure copper, this can result in increased heating due to the harmonic losses seen in the rotor bar tip (Fig. 12). The main disadvantage here would be if the increase in frame size increased the cost to a point where it was greater than cost of the motor with the copper bar rotor. As a rule it is normally much more economical to utilize an ADC rotor on smaller machines. In this application ADC rotors would turn

out to be very reliable and trouble free as long as severe starting duty/high inertia applications are not encountered.

Another point of interest is that many of the special shapes that can be used on motors for across the line starting will increase the rotor losses when running on ASD's. As a result it is common to use rectangular rotor bars or bars that are wider at the rotor OD than the rotor ID on constant torque ASD applications where heating at low speed is excessive. A rotor bar wide at the top that is generally suitable for ASD applications is shown in Fig. 12.

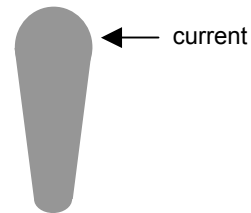

FIG. 12 - Picture of Current Flowing in the Rotor Bar Tooth Tip in an ASD Application

Response to speed change:

Another performance attribute that may lead one to consider an aluminum rotor is the need for quick response to speed change such as may be seen in an ASD application where the process requires a rapid change in speed or emergency stopping. In these applications the lighter rotor with lower WK2 may respond quicker and put less stress on the attached or driven equipment. This is of particular interest if an external brake is being used to stop the equipment or if the driven equipment tends to load up and rapidly slow down such as may be seen in mining applications (such as large drag lines or excavating shovels). In these cases a light weight aluminum rotor may have an advantage.

IX. ROTOR COST COMPARISON

Although four rotor constructions were presented in this paper, the two most common constructions are aluminum die cast and copper bar. As such, a cost comparison will be shown for those constructions only. The cost comparison was performed on standard machines – standard starting duty, NEMA inertia, no special slip or efficiency requirements, etc. Additionally, the cost comparison was conducted taking advantage of superior cooling of the CuBar motor, and the subsequent reduction in core length. The cost comparison is shown as a percentage increase in cost of the CuBar rotor over ADC, with all other features being identical (voltage, service factor, etc.). For example, if a 700 Hp, 2300V, 1.0 SF TEFC motor costs \$20,000 with a ADC rotor and \$24,000 with a CuBar rotor, the motor with the CuBar rotor has a 20% cost increase.

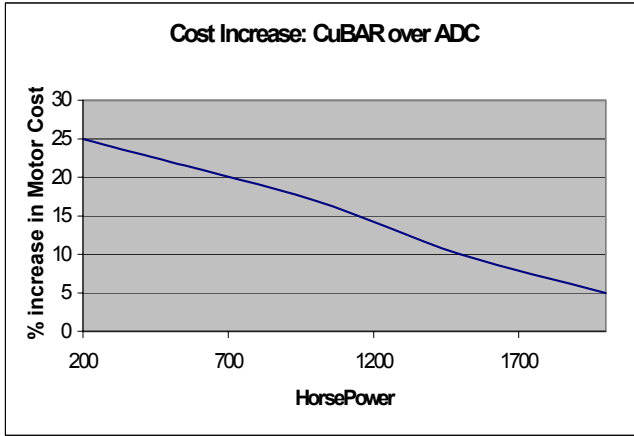

FIG. 13 - Cost Increase of CuBar vs. ADC

X. CONCLUSION

Many topics were addressed in the area of rotor construction. A chart was put together to help summarize the many different facets of rotor construction. The chart below summarizes a comparison between the various rotor constructions. The comparison is a relative one, with a lower number indicating an advantage.

	ADC	ALBar	CuDC	CuBar
Cost	1	2	2	4
Efficiency	2	3	1	1
Design Flexibility	2	4	1	2
Size	2	1	2	1
Tooling/Capital	2	1	3	1
High Inertia/ Multiple Restart	2	2	1	1
Repairability	4	3	4	1

It is impossible to pick 'the best' rotor construction for every situation. By understanding the manufacturing and design tradeoffs, it is possible to select the optimal rotor construction method (one that will yield the desired reliability at the lowest cost) for the particular application.

REFERENCES

- [1] API Standard 541 Third Edition, Form-Wound Squirrel Cage Motors - 250 Horsepower and Larger Washington, D.C., 1995
- [2] NEMA Standards Publication No. MG 1-1993 Rosslyn, VA, 1996
- [3] Hodowanec, M.M., and Bezesky, D.M., "Field Motor Testing: Procedures which Limit Amount of Risk Involved, IEEE IAS PCIC Conference Records
- [4] Craggs, J.L., "Fabricated Aluminum Cage Construction in Large Induction Motors," IEEE Transactions on Industry Applications, Vol. IA-12, No. 3, May/June 1976.

[5] Hartung, E.C., "Fabricated Aluminum Rotor Construction for Induction Motors," IEEE IAS Pulp & Paper Conference Record, 1994.

[6] Bredthauer, J., and Struck, N., "Starting of Large and Medium Voltage Motors Design, Protection and Safety Aspects," IEEE IAS PCIC Conference Record, 1994

[7] Phillip E. Hayes, Barry M. Wood, Dennis G. Horn, "Mechanical Design of Induction Motors Applied on Adjustable Speed Drives," IEEE IAS PCIC Conference Record, 1997

[8] Philip L. Alger "Induction Machines" Gordon and Breach Publishers First published 1965.

[9] Austin H. Bonnett, "Root Cause of A.C. Motor Failure Analysis" IEEE IAS PCIC Conference Record, 1999

[10] Metals Engineering, December 1992

BIOGRAPHY



William R. Finley received his BS Degree in Electrical Engineering from the University of Cincinnati, Cincinnati, OH. Presently, as Manager of Engineering for Siemens Energy & Automation, Bill is responsible for Above NEMA Induction Motor designs. Over the many years in the business he has worked in various Engineering

Design and management positions, including Electrical and Mechanical Design, Product Development, Quotation and Computer Systems. He is a Senior member of IEEE and has previously published 10 technical articles. He is currently active in over 10 NEMA and IEC working groups and Sub-committees. He is Chairman of the Large Machine Group and International Standardization Group of NEMA.



Mark M. Hodowanec received a B.S. and M.S. degree in mechanical engineering from the University of Akron, Akron, OH. Currently, he is the Manager of Mechanical Engineering for ANEMA induction motors built in the U.S. at Siemens Energy and Automation, Inc., Cincinnati, OH. For the past nine years he has worked in a variety of

engineering positions including design, product development, order processing, shop testing, and field support. He is currently active on various NEMA, IEEE, and API working groups. In addition to his ANEMA motor experience, Mr. Hodowanec has worked on a wide assortment of induction motors such as NEMA, submersible, and MSHA motors. He is the author of several published technical articles.

TABLE I
PERFORMANCE VS. ROTOR CONDUCTIVITY STUDY
WITH STATOR DESIGN UNCHANGED

	ADC	ADC Bar Shape Same as Cu Bar	CDA 110	CDA 210	CDA 220	CDA 230	CDA 464	CDA 510
Relative Resistance	1.8R	1.8	1.0R	1.79R	2.273R	2.727R	3.85R	6.66R
LRT %	70	75	60	71	76	80	89	115
BDT%	267	263	284	280	276	277	275	269
LRA%	570	551	593	573	564	557	545	524
Depth Of penetration for current inches	.497	.502	.38	.516	.595	.665	.813	1.03
W&F	5.34	5.34	7.48	7.48	7.48	7.48	7.48	7.48
Slip Losses (kW)	19	11.5	6.7	11.1	13.8	16.5	22.9	39.8
Total Losses (kW)	46.1	49.2	45.9	50.4	53.2	55.8	62.4	79.8
Eff. % @ FL	96.0	95.8	96.1	95.7	95.5	95.2	94.7	93.3
Slip % @ FL	0.833	1.0	0.59	0.96	1.20	1.40	1.97	3.38
Rise by resistance @ FL (deg°C)	59	60	57	69	71	76	78	89
Rise Per Accel. Rotor Bar	85.4	121	84	86	88	90	92	94
Rise Per Accel. Rtr. End Connector	41.2	36	21	17	15	14	11	08
Rise Per Accel. Stator copper	26.7	23	32	25	22	20	16	11
Rotor Bar Area	.695 In ²	.508 In ²	.508 In ²	.508 In ²	.508 In ²	.508 In ²	.508 In ²	.508 In ²

Table I assumes all heat is stored in rotor bars and rises are an average and load curve and WK² is equal to that recommended by NEMA

TABLE II
MATERIAL CHARACTERISTICS WHICH AFFECT THE ELECTRICAL AND MECHANICAL DESIGN OF INDUCTION MOTOR CAGE
WINDINGS

Characteristics	Pure Aluminum ¹ *	Ranges for Aluminum Alloys Commonly Used in Cage Construction ¹	Pure Copper ² **	Ranges for Copper Alloys Commonly Used in Cage Construction ²	Electrical Steel
Electrical Conductivity, % IACS @ 20°F	62	34-59	101	7-90	—
Specific Heat, BTU/Lb. °F. @68° F	0.233	0.233	0.092	0.09	—
Density, Lb./In. ³ @68° F	0.098	.097-.098	0.323	.308-.323	.284
Melting Point, °F	1195-1215	1080-1210	1981	1880-2100	—
Coef. Of thermal expansion, /° C	23.8 x 10 ⁻⁶	23.4-23.6 x 10 ⁻⁶	17.6 x 10 ⁻⁶	17.3-18.7 x 10 ⁻⁶	11.2 x 10 ⁻⁶
Coef. Of thermal expansion, /° F	13.2 x 10 ⁻⁶	13.0-13.1 x 10 ⁻⁶	9.8 x 10 ⁻⁶	9.6-10.4 x 10 ⁻⁶	4.26 x 10 ⁻⁶
Thermal expansion mils/in/100° C	2.38	2.34-2.36	1.76	1.73-1.87	1.12
Thermal Conductivity, BTU/Ft. ² /ft/hr/° F	135	78-128	226	21-208	—
Yield Strength, psi x 1000****					
Annealed	4	7-17	10	10-21	—
Tempered	24	28-40	53	57-80	—
Ultimate Strength, psi x 1000					
Annealed	12	14-36	32	34-56	—
Tempered	27	32-45	57	60-92	—
Elongation, % in 2"					
Annealed	23	22-25	45-55	45-63	—
Tempered	1.5	10-15	4-40	3-10	—
Fatigue endurance limit, psi x1000****	7	9-16	11-17	15-31	—

* Data for Electrical Conductor Grade; 99.45% minimum aluminum.

** Data for CDA Alloy No. 102, Oxygen Free; 99.95% minimum copper.

*** Fatigue limit for aluminum products is based on 500x10⁶ cycles. For copper products it is based on 100x10⁶ cycles

**** Yield Strength is at 0.2% offset for aluminum products and at 0.5% ext. under load for copper products

Note conductivity is the inverse of resistance